

Modern Instruments

THE THERMOKINETIC REACTOR TKR AND ITS POSSIBLE APPLICATIONS IN CHEMICAL RESEARCH AND ENGINEERING

W. Litz

ENGINEERING DEPARTMENT APPLIED PHYSICS, BAYER AG, D-5090
LEVERKUSEN-BAYERWERK, GFR

(Received January 25, 1983)

A reactor-calorimeter is described which makes it possible to perform accurate measurements of the thermal power (rate of heat evolution) of chemical and physicochemical processes in essentially fluid reaction systems to be carried out a) continuously under isothermal conditions, b) without interfering with the course of the reaction, c) using large quantities of reaction mix, d) allowing for considerable variations in the consistency and/or the volume of the mix during reaction, e) providing for conditions which are very close to those of industrial practice. In addition, the equipment provides information on the heat transmittance of the reactor and the stirring power.

It is well known that thermoanalytical methods are being increasingly used in process development in the chemical industry, to determine "technically oriented" reaction mechanisms with the respective rate laws for the optimization of reactors, and, at the same time, to determine caloric data for the thermal dimensioning of plants and to establish safety measures [1-6].

However, conventional equipment of this type for fluid systems is of only limited use in obtaining sufficiently accurate data utilizable for chemical process analysis, since in some devices the quantity to be tested is very small (unrealistic surface/volume ratio, uneven temperature distribution within the test mix, etc.) and it is not possible to simulate technical conditions (exact starting time of the reaction, dosing of additional reactant as well as sampling during the course of the reaction, stirring, reflux, etc.). In other devices, the reaction mixture is not allowed to deposit material on the reactor wall during reaction, or to undergo any major change in its physical properties at the start of or during the measurement (volume of reaction mass, degree of dispersion, viscosity, density, specific heat, etc.). In other cases, the measurement methods are based on simplified theories [2, 3, 7-13].

To eliminate some of these major weaknesses, manipulative methods are employed in the evaluation of recorded curves (use of appropriately curved reference lines, etc.) and/or during the measuring operations themselves (intermediate calibration, etc.). Such procedures can, however, only reduce the existing inaccuracy of the evaluated

results; even then, they may still be of little use. Beyond this, intervention during the measurement can lead to changes in the reaction conditions, which should remain constant so that the generally complex reaction can be analysed as simply and as accurately as possible.

Principle of measurement

The thermokinetic reactor TKR does not display the limitations and disadvantages just described. The TKR functions essentially according to the principle of compensation [14]: A reactor is inserted in a thermostat, which to be precise is an intermediate thermostat, as it is, in turn, immersed in a base thermostat (Fig. 1). The reactor consists of a chamber provided with a stirrer, a controlled electric heater and a temperature sensor. The intermediate thermostat is designed in exactly the same way. The temperature T_0 of the base thermostat is maintained at a constant set value via a control loop. The controlled heating power L_1 of the intermediate thermostat maintains a constant set temperature difference ΔT_{10} between the intermediate thermostat and the base thermostat, while the controlled heating power L_2 in the reactor maintains a constant set temperature difference ΔT_{20} between the reactor and the intermediate thermostat. The reactor displays the highest temperature, $T_0 + \Delta T_{10} + \Delta T_{20}$, the intermediate thermostat a medium temperature, $T_0 + \Delta T_{10}$, and the base thermostat the lowest (base) temperature, T_0 . Corresponding to the constant temperature difference ΔT_{20} , the heat $(kF)_2 \cdot \Delta T_{20}$ flows from the reactor to the intermediate thermostat and, corresponding to the constant temperature difference ΔT_{10} , the heat $(kF)_1 \cdot \Delta T_{10}$ flows from the intermediate thermostat to the base thermostat. During the course of a reaction, the following applies for the balance of thermal power (in control equilibrium)*

$$\text{a) reactor} \quad q + L_2 + L_{R2} = (kF)_2 \cdot \Delta T_{20} \quad (1)$$

$$\text{b) intermediate thermostat} \quad (kF)_2 \cdot \Delta T_{20} + L_1 + L_{R1} = (kF)_1 \cdot \Delta T_{10} \quad (2)$$

$(kF)_1$ and L_{R1} are constant; ΔT_{10} and ΔT_{20} are maintained unchanged by appropriate adjustment of L_1 and L_2 via two PID control loops to the evolved thermal reaction power q as well as to the stirrer power L_{R2} within the reactor and the heat transmittance $(kF)_2$ between the reactor and the intermediate thermostat, which both change inevitably as a result of the changing physical properties of the reaction mix.

Therefore Eqs (1) and (2) result in

$$\begin{aligned} q(t) &= [(kF)_1 \cdot \Delta T_{10} - L_{R1}] - [L_1 + L_2 + L_{R2}] = \\ &= [L_1 + L_2 + L_{R2}] \quad - \quad [L_1(t) + L_2(t) + L_{R2}(t)] \end{aligned} \quad (3)$$

prior to
start of
reaction

during
course of
reaction

* List of symbols at the end of the paper.

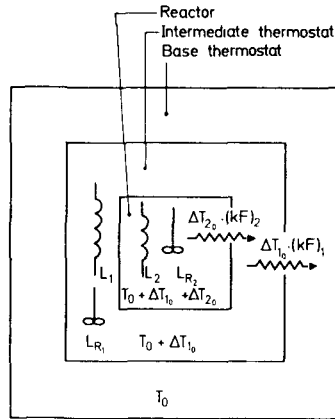

Fig. 1 Working principle

The stirring power L_{R2} is determined by the current of the stirrer drive motor which is kept at constant rotational velocity via a control loop: the total torque D of the stirring equipment is proportional to the current J

$$D = D_I + D_U = dJ$$

D_I consists of the internal loss moment of the motor (eddy current, bearing) and the friction loss of the stirrer shaft bearing, both depending essentially on the rotational velocity; D_U is the useful torque for stirring. The torque factor d is a constant for a motor without armature reaction. If ω is the angular velocity, the total power L_M is therefore given by the formula:

$$L_M = D(\omega) \omega = (D_I(\omega) + D_U) \omega = D_I(\omega) \omega + L_R = dJ\omega \quad (4)$$

If the angular velocity is kept constant and the shaft bearing designed so as to prevent it from becoming soiled with reaction mix, the torque loss of the stirrer shaft remains constant during the experiment. This is ensured by connecting motor and stirrer *via* a magnetic coupling. The magnetic coupling consists of two permanent magnet rings mounted in bearings one above the other, the lower one in a hastelloy shell within the reactor cover. The shell is open at the top centre, closed at the bottom and connected to the stirrer shaft at this point. The stirrer shaft is borne and guided by a ball-bearing column, which is located above the lower magnet ring inside an additional cylindrical bulge in the reactor cover, and whose lower section reaches down into the magnet ring space filled with silicone fluid. The centrifugal force of the lower magnet ring prevents liquid from the reactor penetrating the area surrounding the ball bearings; vapours which penetrate are absorbed in the silicone fluid layer.

Thus, at constant angular velocity, Eq. (4) results in:

$$L_R = L_M - \text{const.} \quad (5)$$

Consequently, the thermal reaction power $q(t)$ of Eq. (3) is determined by the difference between the sum of the heating powers in the reactor and the intermediate thermostat and the motor power of the reactor *prior to the start of reaction*, and the sum of these powers *during the reaction*

$$q(t) = [L_1 + L_2 + L_{M2}]_p - [L_1(t) + L_2(t) + L_{M2}(t)] = L_p - L(t)$$

with $L_p = \text{const.}$ (6)

Using special heater systems (lead, heating section, lead with resistance ration 1/600/1) with virtually no thermal inertia, and DC power supplies, the heating powers L_1 and L_2 are obtained by electronically multiplying the heater current by the voltage. The motor power L_M is obtained by the electronic multiplication of the torque factor d , the current J and the angular velocity ω .

In practical application, the method is applied by adding the three different voltages L_1 , L_2 and L_{M2} and feeding the result into a potentiometric recorder. $|q(t)|$ corresponds to the distance of the measured curve L from the constant line L_p (Fig. 2). If L_p is compensated by an adjustable voltage reference, only the desired thermal reaction power $q(t)$ is recorded.

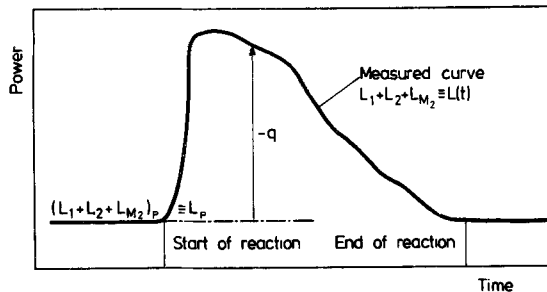

Fig. 2 For determination of the thermal reaction power from the sum of the heater power L_2 of the reactor and L_1 of the intermediate thermostat as well as the motor power L_{M2} of the reactor

Examples of experimental results and discussion

The physical conditions change to a greater or lesser degree of complexity during the course of any chemical or physico-chemical reaction and this is the reason for the multiform deviation of the base line with any calorimeter. Thus, approximated procedures (e.g. laying down of an appropriately curved base line, generally accomplished with conventional devices) will lead to a correspondingly more or less incorrect thermal analysis. An insight into the variety of base lines can be obtained by dissecting some experimental results of the TKR. To illustrate this more clearly, the theoretical

basis of the TKR has to be explained somewhat differently. According to the power balance of the reactor in Eq. (1), the gross deviation of the heating power L_2 from its value L_{2p} prior to the start of reaction is caused partly by the onset of the thermal reaction power q and partly by the change in the heat transmittance $(kF)_2 \hat{=} 1/R$ (i.e. in the heat flow $(kF)_2 \cdot \Delta T_{20}$ at constant ΔT_{20}) as well as the stirring power L_{R2} :

$$\delta L_2 = [\delta(kF)_2 \cdot \Delta T_{20} - \delta L_{R2}] - q \quad (7)$$

It can easily be seen from the power balance of the intermediate thermostat in Eq. (2) that the change in the heat flow $(kF)_2 \cdot \Delta T_{20}$ is inversely congruent with the deviation of the controlled heating power L_1 of the intermediate thermostat from its value L_{1p} prior to the start of reaction:

$$\delta(kF)_2 \cdot \Delta T_{20} = -\delta L_1 \quad (8)$$

and from Eq. (5) that the change in the stirring power of reactor L_{R2} is equal to the change in the motor power L_{M2} (Fig. 3a):

$$\delta L_{R2} = \delta L_{M2} \quad (9)$$

Thus, eq. (7), (8) and (9) give

$$\delta L_2 = -(\delta L_1 + \delta L_{M2}) - q = \delta L_{B2} - q \quad (10)$$

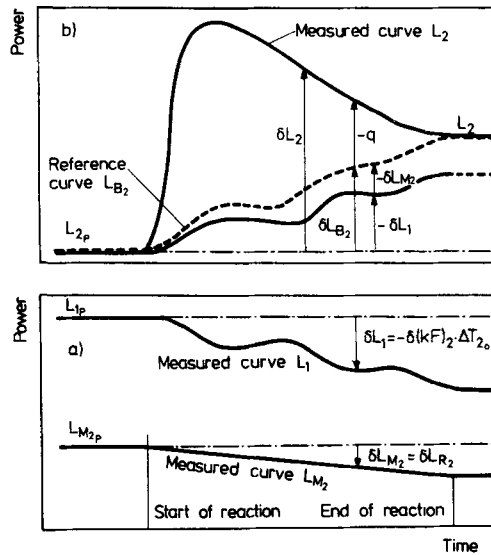

Fig. 3 For determination of the thermal reaction power q solely from the heater power L_2 of the reactor. Effect of the change in thermal transmittance $(kF)_2$ and motor power L_{M2} on the reference line L_{B2}

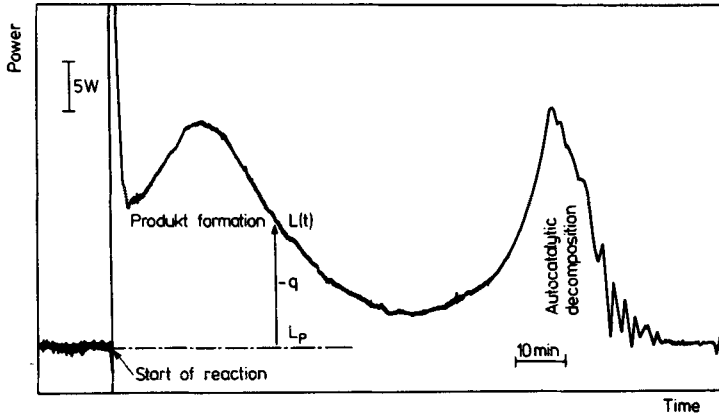

Fig. 4 Friedel-Crafts alkylation followed by autocatalytic decomposition

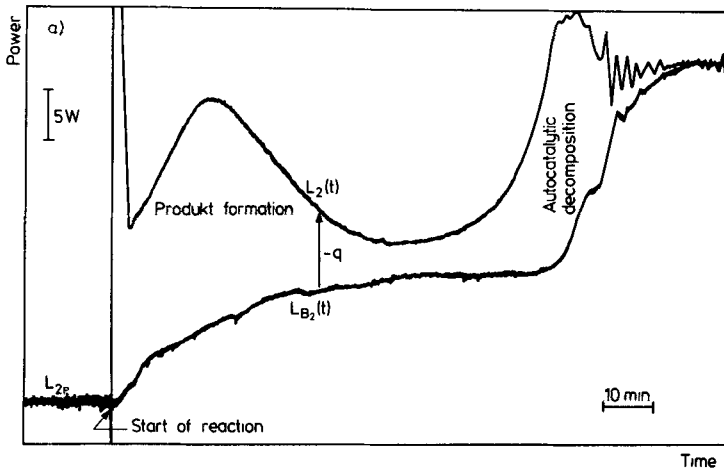

Fig. 4a Dissection of TKR measurement in Fig. 4

This means that the dotted line in Fig. 3b (dissection of Fig. 2) represents the course of L_2 during the reaction caused *solely* by the change in both the heat flow (i.e. heat transmittance) and the stirring power, that is to say the course of the base line L_{B_2} , which is needed in order to accurately determine the thermal reaction power q solely from the heating power L_2 .

The course of the reference line L_{B_2} is obtained experimentally by adding L_1 and L_{M_2} , feeding L_2 and $(L_1 + L_{M_2})$ with opposite signs into a two-channel potentiometric recorder and shifting $-(L_1 + L_{M_2})$ over L_{2p} by zero shift before the start of reaction.

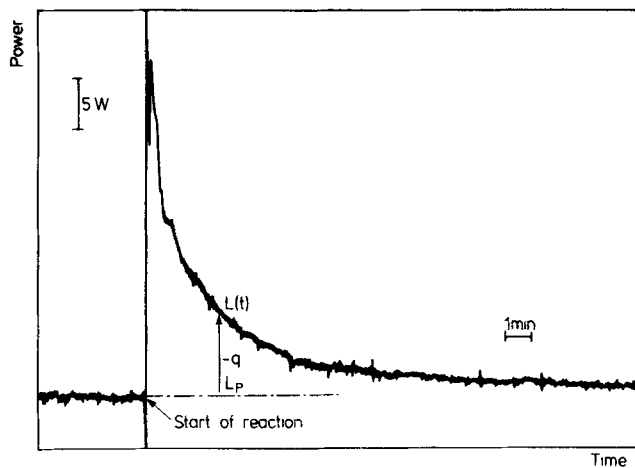

Fig. 5 Nucleophilic substitution at a keto- α -halide with an amine derivative in the presence of the auxiliary base KOH in solution

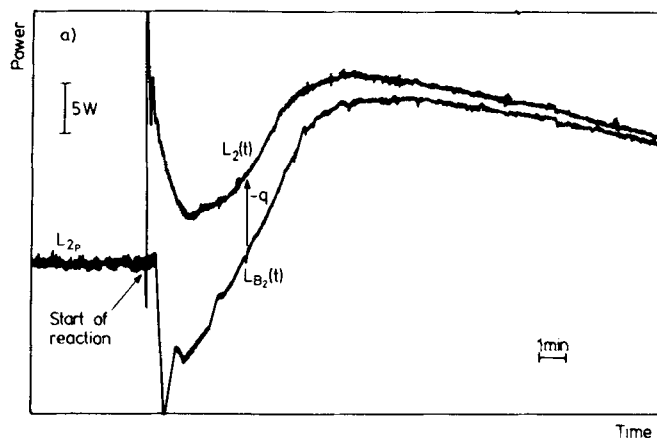

Fig. 5a Dissection of TKR measurement in Fig. 5

Figures 4–8 show some TKR measurements and Figs 4a–8a the corresponding dissected measurements, clearly demonstrating that totally incorrect information may be obtained if the precise course of the reference line is not known, e.g. if the base line is of necessity positioned in an approximated or even estimated location.

The major part of the deviation of the base line L_{B_2} from its value prior to the start of the reaction is usually caused by the change in the heat transmittance $(kF)_2$. Nevertheless, the influence of the stirring power L_{R_2} must be taken into account,

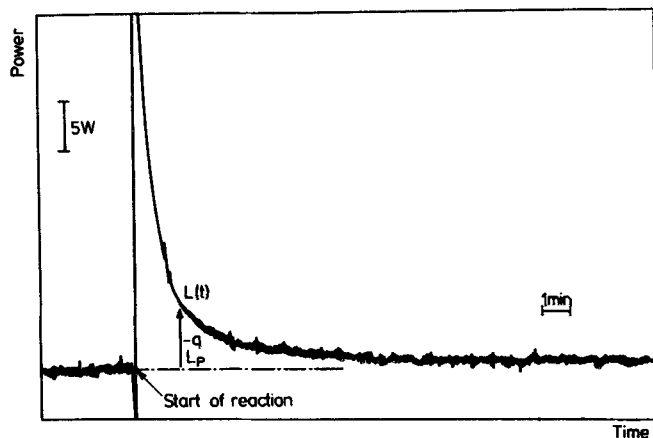

Fig. 6 Nucleophilic substitution at a keto- α -halide (as in Fig. 5) with the same amine derivative but in the presence of the auxiliary base K_2CO_3 in solution

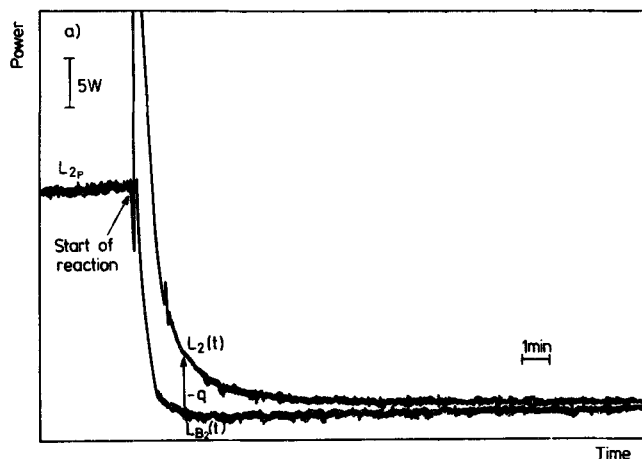

Fig. 6a Dissection of TKR measurement in Fig. 6

because it may become considerable in the cases of polymerization, phase separation, crystallization, or if the reaction starts in such a manner that a large quantity of reactant has to be fed into the reactor chamber which is prefilled with only a relative small quantity of co-reactant; if it is necessary to take (e.g. for classical chemical analysis) many samples; or if industrial practice is to be simulated; etc. (Fig. 9).

Thus, with any calorimeter, it goes without saying that only accurate determination of the base line makes it possible to get reliable and therefore mathematically utilizable data.

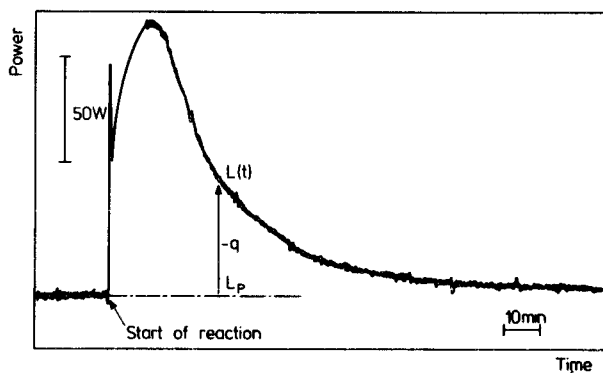

Fig. 7 Catalytic intramolecular rearrangement of an amide derivate

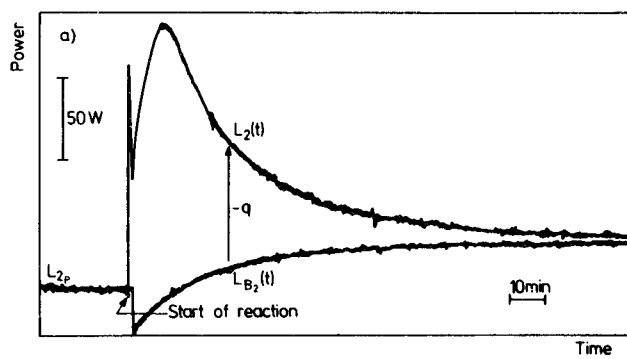

Fig. 7a Dissection of TKR measurement in Fig. 7

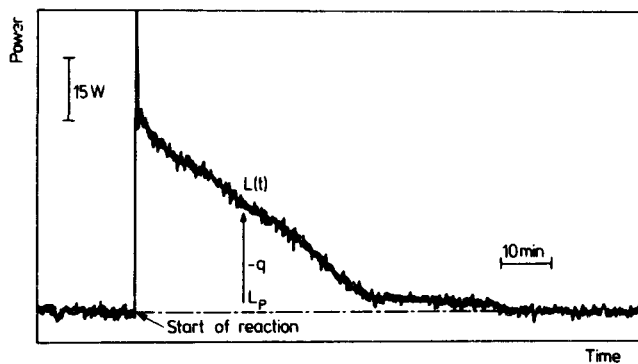

Fig. 8 Catalytic hydrogenation of a nitrile group

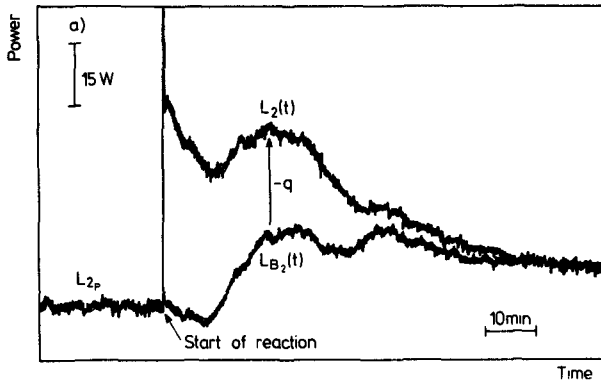

Fig. 8a Dissection of TKR measurement in Fig. 8

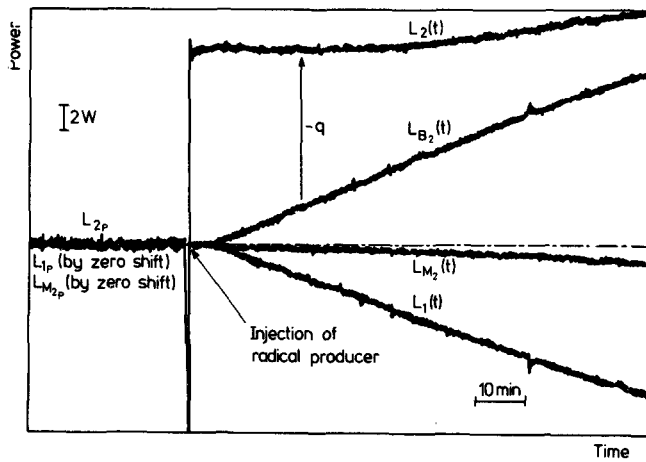

Fig. 9 Radial bulk polymerization (Dissection measurement)

Besides the accurate determination of the thermal reaction power q , the TKR provides information on the heat transmittance and the stirring power, Eqs (1) and (4), and on their variation during the course of the reaction (Eqs (8) and (9)).

This additional information is of great importance from the point of view of design and safety in chemical engineering.

Examples of TKR design

Two different designs of TKR have been successfully used in our laboratories. In one design the reactor and the intermediate thermostat are totally surrounded by the base thermostat to ensure a high accuracy (Fig. 10). There is no *simple* way of visualizing particular events within the reactor (onset of phase separation, change in colour, deposition of material on the reactor wall, etc.), which very often provide chemists and engineers with a great deal of information. Because of this, in the other design, the reactor is surrounded by part of the intermediate thermostat, a jacket,

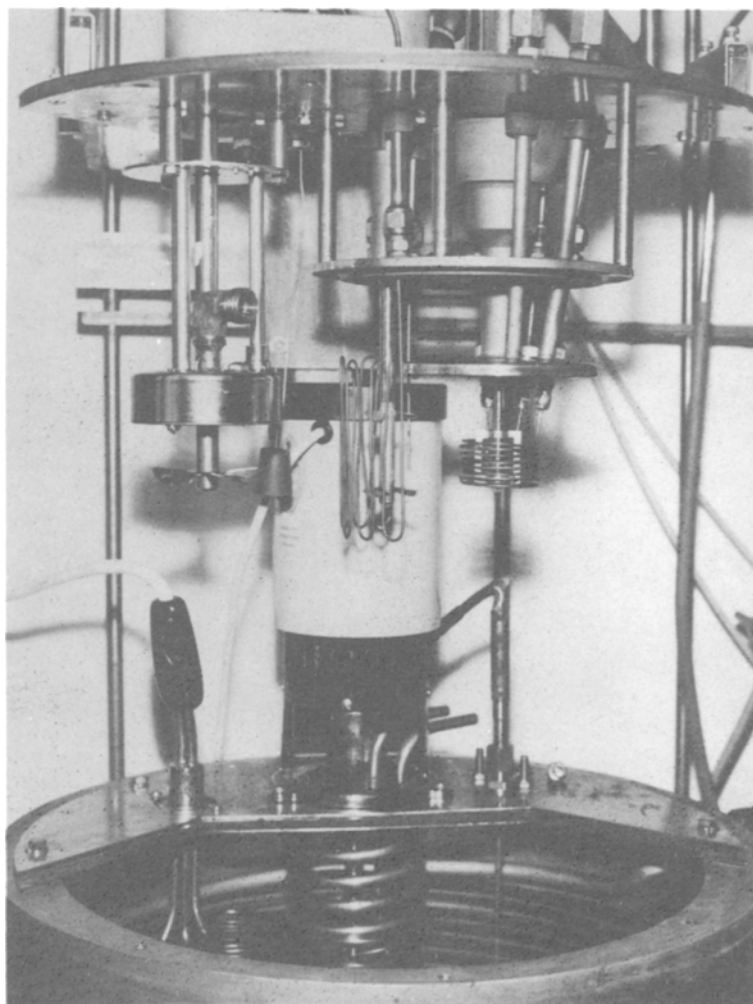

Fig. 10 TKR type preferably used for kinetic investigation

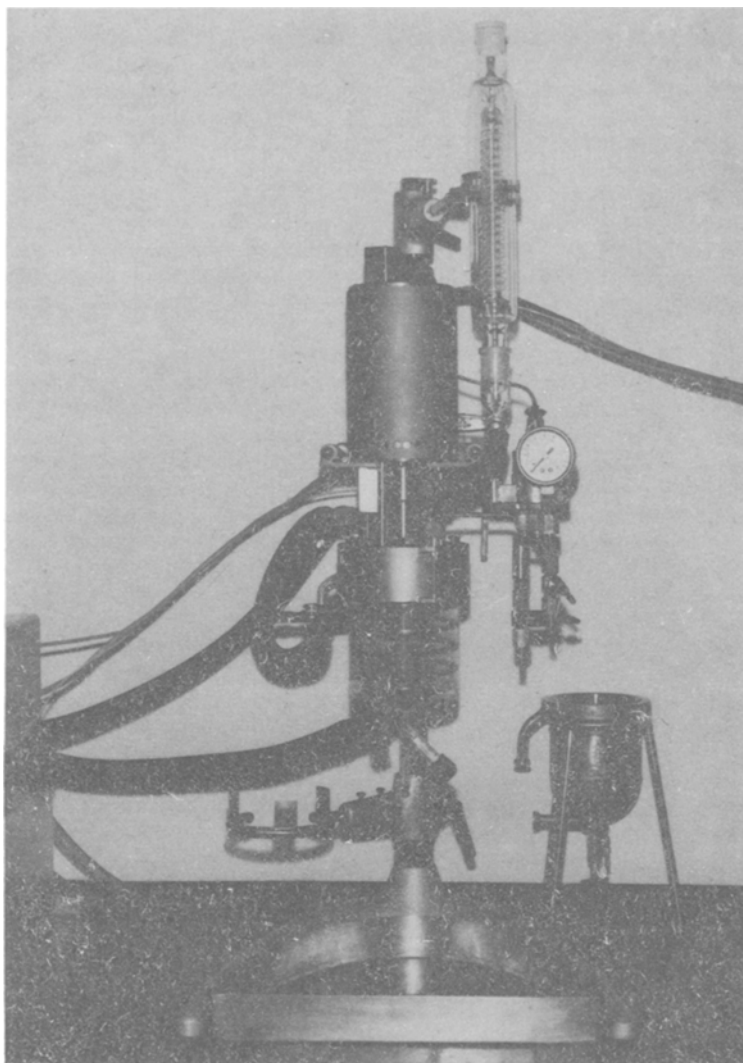

Fig. 11 TKR type preferably used for simulation of industrial practice

which, for pressureless reactions, is made of glass; this is connected by a pipe to the core of the intermediate thermostat, which is totally enclosed by the base thermostat (Fig. 11). This type is normally used for simulation of industrial practice.

The essential characteristics of the instruments used are as follows:

- Material of reactor, jacket: glass for pressureless reaction,
hastelloy for reaction under pressure
- Reactor volume: 100 → 1000 ml

- Range of operating temperature: – 40 → 300°
- Maximum rotational velocity: 4000 rev/min
- Maximum compensatory heating power: 400 W
- Maximum operating pressure: 15 bar
- Endothermic and exothermic chemical and physicochemical reactions can be carried out in the following phase systems: liquid/gas, liquid/liquid, liquid/solid, liquid/solid/gas, with the liquid phase predominating.
- Reactions with half-lives in excess of two minutes proceed under strictly isothermal conditions virtually throughout the reaction time, except in the first moments of the reaction. Temperature fluctuations around the set point are usually of the order of 10–2°. This isothermal character is the necessary and sufficient condition (guarantee) for the correctness of the measured thermal reaction power q .

Applications

The TKR is used not only for measuring the thermal reaction power q under (virtually) strictly isothermal conditions, e.g. for isothermal reaction kinetics, or evaluating the heat transmittance and stirrer power, but, for instance, also for

- anisothermal investigation of reaction kinetics,
- determination of reaction enthalpy,
- determination of dissolving, mixing and crystallizing enthalpy,
- determination of specific heat of reaction mix,
- approximate testing of process procedures and safety measures for technical production by simulation of the process under conditions similar to those prevailing in industrial practice: Batch-, semi batch- and steady state processes. For this purpose metering and sampling devices and reflux condensers combined with thermal power balance, pH-meter etc. can be connected,
- rationalizing preparatory work in the laboratory, e.g. making the end of a reaction easily recognizable: final analysis can be carried out at the right time, e.g. without the need for what is known as "post-stirring", which is uneconomical.

List of symbols

d	torque factor
D	total torque
D_u	useful torque
D_l	torque loss
J	current
F_1, F_2	effective heat exchange area of intermediate thermostat, reactor
k_1, k_2	heat exchange coefficient of intermediate thermostat, reactor
$(kF)_1, (kF)_2$	heat transmittance of intermediate thermostat, reactor

L_1, L_2	heating power of intermediate thermostat, reactor
L_{R1}, L_{R2}	stirring power of intermediate thermostat, reactor
L_{M1}, L_{M2}	motor power of intermediate thermostat, reactor
L	$L_1 + L_2 + L_{M2}$ during course of reaction
L_p	$L_1 + L_2 + L_{M2}$ prior to start of reaction
L_{B2}	reference line for the heating power L_2
p	index characterizing situation prior to reaction start
q	thermal reaction power
R	thermal resistance (reactor/intermediate thermostat)
T_0	temperature of base thermostat
t	time, as from start of reaction
ΔT_{10}	set temperature difference intermediate thermostat/base thermostat
ΔT_{20}	set temperature difference reactor/intermediate thermostat
ω	angular velocity (motor)

Reference

- 1 F. Becker, Chem. Ing. Techn., 40 (1968), 933.
- 2 W. Köhler, O. Riedel and H. Scherer, Chem. Ing. Techn., 45 (1973) 128.
- 3 W. Litz and D. Biehler, German Offenlegungsschrift, 2355952 (1973).
- 4 W. Regenass, Thermochim. Acta, 20 (1977) 65.
- 5 E. Koch, Non-isothermal Reaction Analysis, Academic Press, London, 1977.
- 6 G. Giger, A. Aichert and W. Regenass, Swiss Chem., 4 (1982) Nr. 3a, 33.
- 7 E. S. Watson, M. J. O'Neile, J. Justin and N. Brenner, Anal. Chem., 36 (1964) 1233.
- 8 W. Regenass, German Offenlegungsschrift, 2332135 (1973).
- 9 L. Hub, J. Chem. E. Symp. Ser., 49 (1977) 39.
- 10 M. I. Pope and M. D. Judd, Differential Thermal Analysis, Heyden & Sons, 1977.
- 11 G. N. Gusenkov and G. A. Krestov, J. Thermal Anal., 13 (1978) 369.
- 12 B. Hentschel, Chem. Ing. Techn., (1979) MS 725.
- 13 J. Schildknecht, Thermochim. Acta, 49 (1981), 87.
- 14 W. Litz, German Offenlegungsschrift, 3049105 (1980).

Zusammenfassung — Es wird ein Reaktorkalorimeter vorgestellt, das die *genaue* Bestimmung der thermischen Reaktionsleistung (Wärmeproduktionsrate) von chemischen und physikalisch-chemischen Vorgängen erlaubt

- a) an präparativen, im wesentlichen flüssigen Reaktionssystemen
- b) unter Bedingungen, die sich an solche der technischen Prozessführung anlehnen
- c) praktisch unter strenger Isothermie
- d) kontinuierlich und ohne Störung des Reaktionsgeschehens
- e) wobei grosse Konsistenz- und/oder Volumenänderungen bei Reaktionsstart oder während des Reaktionslaufs eintreten dürfen.

Das Gerät ermöglicht zudem die Bestimmung der Rührleistung und der Wärmedurchlässigkeit des Reaktors.

Резюме — Описана аппаратура, позволяющая проводить точные измерения теплотворной способности химических и физико-химических процессов в жидких реакционных системах. Измерения могут выполняться непрерывно в изотермических условиях, без побочного влияния хода реакции, при использовании больших количеств реакционной смеси, при значительных изменениях консистенции или объема смеси во время реакции, а также в условиях близких к заводским. К тому же, с помощью этой аппаратуры можно получить информацию о теплообмене и мощности мешалки.